

R.A.C. Recognition No. 296
Valid From 8/1/81



ROYAL AUTOMOBILE CLUB

3 Begrave Square, London, SW1X 8QH

SAFETY ROLL BAR CERTIFICATE

Manufacturer SAFETY DEVICES Roll bar model No/Designation 3/5R
Car/s for which roll bar is designed
Make/s BRITISH LEYLAND
Model/s MINI METRO
F.I.A. Homologation No/s
Weight of Car/s lbs. lbs. lbs.
kgs. kgs. kgs.

ROLL BAR SPECIFICATION

Main tube Dia. 1.5 ins. 38 mm. Brace/s Dia. 1.5 ins. 38 mm.
Thickness .108 ins. 2.6 mm. Thickness .108 ins. 2.6 mm.
Type of welding M. I. G. Weight of total assembly 34 lbs 15.42 kgs
Material Specification CDS 2 BS980

DECLARATION BY DESIGNER for Roll Bars not complying with F.I.A. design details

I declare that the roll bar described has been *
(a) tested under my personal supervision
(b) shown by my own stress calculations
or (c) shown by stress calculations carried out under my personal supervision
to meet the strength requirements specified in current F.I.A. regulations. In addition, I declare
that all details of the roll bar design including joints, mountings and attachments are also in con-
formity with these regulations.

* Delete as appropriate
Date 5TH JANUARY 1981 Signature P. F. JOWITT Name P. F. JOWITT
Professional Qualifications C.Eng., F.R.Ae.S., F.I.Prod.E., F.I.Q.A., M.I.Mech.E.

Acceptable signatories must be a Corporate Member of the Royal Aeronautical Society or the Institution of Civil, Mechanical or Structural Engineers.

DECLARATION BY MANUFACTURER

I declare that the roll bar described is in conformity with the F.I.A. regulations as to design.
Date Signature Name
Status

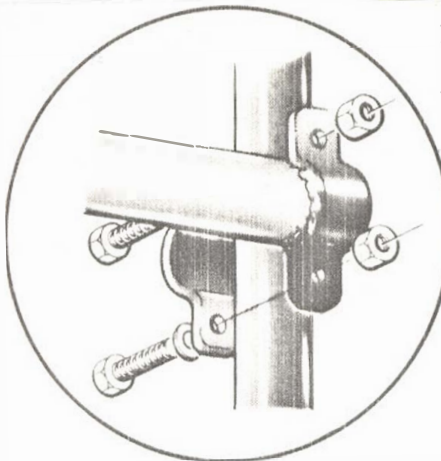

ROLL BAR SPECIFICATION:
ADDITION.

The section forward of the driver position will be manufactured from:-

- 1.5 ins. 38mm diameter
- .084 ins. 2mm thickness
- ERW Mild Steel Tube.

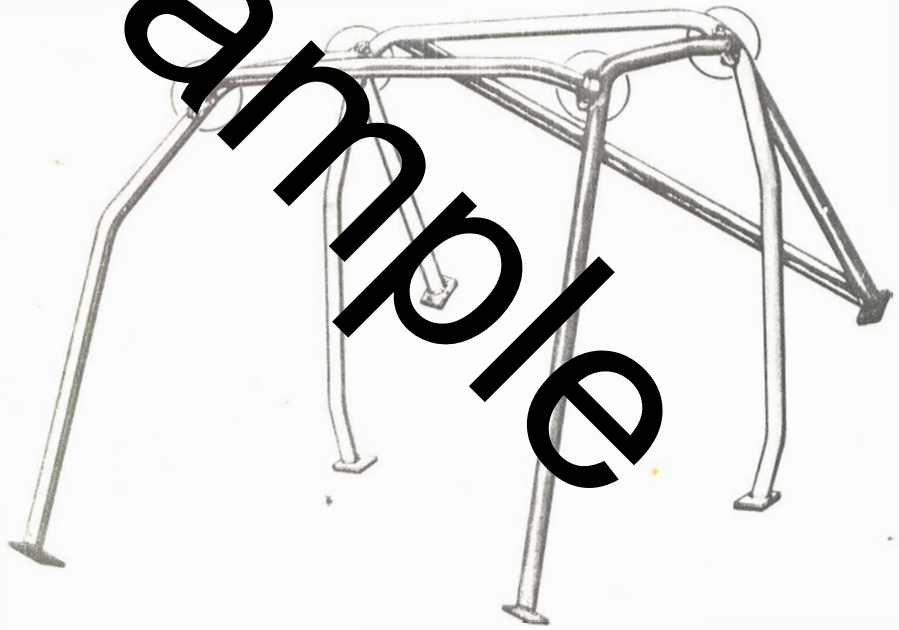

Drawing of roll-bar including details of joints and mountings.

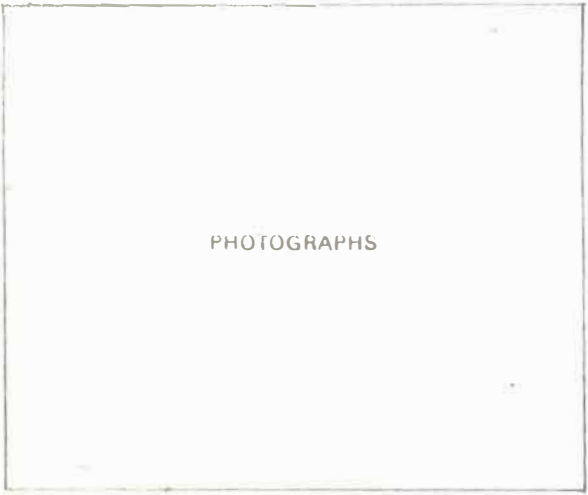

PHOTOGRAPHS

(Signed)

S. Jowitt

R.A.C. GROUP 1 SCRUTINEER

(Countersigned)

